



**CXO300**  
*diesel v8*

**THE  
REVOLUTION  
BEGINS**

**Built with purpose**

**CXO300** – the world's first  
300hp diesel outboard

 **COX**

**Introducing the CXO300  
diesel outboard  
- exceptional  
performance with  
the reassurance of  
proven V8 diesel  
technology**





**25% LESS FUEL**



**300HP**



**480FT.LB TORQUE**



**V8 ENGINE**



**3x LONGER LIFE**



**COMMERCIALY RATED**

**CXO300**  
Company snapshot



**CXO300** – the world's first  
300hp diesel outboard

# COX POWERTRAIN



**£85m  
investment**



**49 expert  
engineers**



**Privately  
owned**



**Founded  
in 2007**



**Located in the  
United Kingdom**



**Cox representation  
in 100 countries**

**CXO300**

A story of British innovation

● **2007**

**HOW IT  
ALL BEGAN**

Motor racing engineer David Cox formed Cox Powertrain with a vision to develop lightweight diesel engines using F1 technology.

● **2008**

**VISION TURNED  
INTO REALITY**

Charles Good starts as Chairman for Cox and initiates the path towards diesel outboards and achieves £5m investment through private financial funding.

● **2010**

**FIRST  
FIRE**

The first fire of Cox's concept engine and commencement of designs for the Alpha engine.

CXO300 – the world's first  
300hp diesel outboard

[coxmarine.com](http://coxmarine.com)

• 2013

### **ALPHA ENGINE**

Alpha engine demonstrations begin and a more defined beta design was developed

• 2014

### **SIGNIFICANT GROWTH**

Tim Routsis became CEO, driving the business on and taking on new premises at Shoreham (Brighton City) Airport.

• 2016

### **DISTRIBUTION NETWORK**

Work to secure a global distributor network commences with an expected 40 distributors worldwide to support the CXO300.

• 2018

### **GLOBAL LAUNCH**

The first pre-production units of the CXO300 were built, with landmark validation programmes starting from key marine influencers. The CXO300 launched globally in November 2018.

**CX<sup>o</sup>300**  
Diesel reliability

# FULLY COMMITTED TO OUR PRODUCTS

CX<sup>o</sup>300 – the world's first  
300hp diesel outboard

[coxmarine.com](http://coxmarine.com)





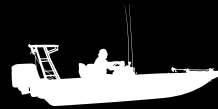

**Recreational warranty  
5 years**



**Commercial warranty  
18 months / 1500 hours**

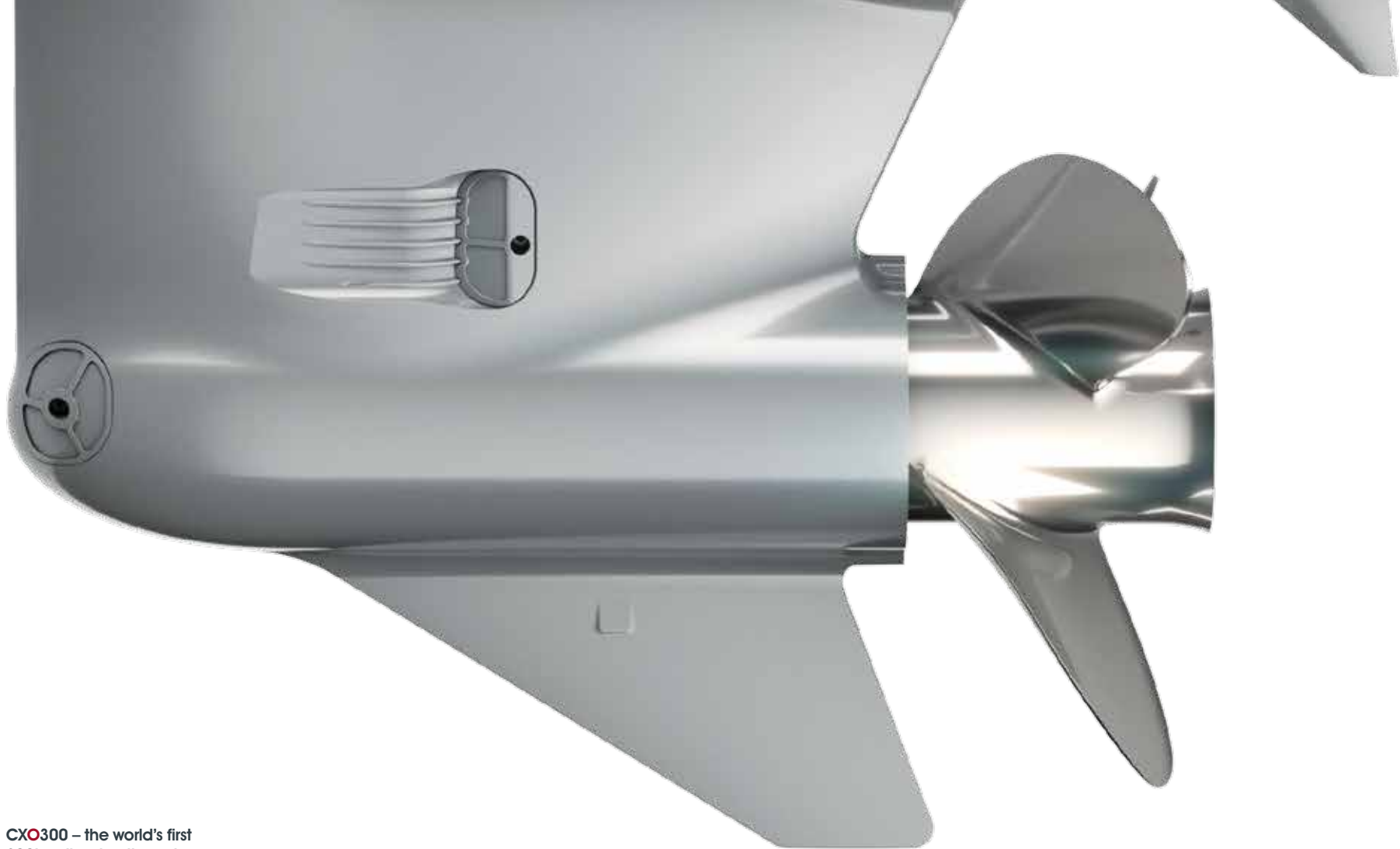

**CXO300** – the world's first  
300hp diesel outboard

# RETROFIT COMPATIBILITY

Although the first of its kind, as the most powerful diesel outboard brought to the market, the CXO300 has been developed to be compatible with existing industry standards – making it as easy to install on a wide range of vessels as any gasoline outboard.



**DIESEL**  
Standard pump diesel.



**NMEA**  
NMEA 2000 compatible.



**TRANSOM**  
Standard outboard fitting layout. 6-bolt mounting with multi-hole adjustment.



**PROP**  
Off the shelf. Maximum propeller diameter 16". 1.25" shaft / 19 tooth.



**STEERING**  
Compatible with all Seastar EPS steering.



**CXO300**  
World class

# REDEFINING THE STANDARDS IN SERVICE

When purchasing a Cox diesel outboard you are buying more than an engine, you are acquiring a new level of service and care that comes standard with all our products. We have defined service standards to ensure you don't lose a week's worth of revenue, or that fishing weekend you have been planning for weeks, because your engine is down.

As a result Cox customers will be able to raise a claim through a push of a button and be assigned a case manager whose sole purpose

is to manage the case every step of the way and get your engine up running as quickly as possible. The Cox after sales team will have real time visibility of each and every case to ensure our service standards are being met by our dealer network wherever you are in the world. We offer an engine substitution programs for those customers who cannot afford down time and a true 24/7 customer service to ensure there is always somebody available to attend our customers no matter the time of day, or night.

**CXO300** – the world's first  
300hp diesel outboard

[coxmarine.com](http://coxmarine.com)

**Air filter**  
Washable and reusable



**100A alternator output**



**4.4l engine**

**Twin turbo**



**Common rail**

**Transmission oil service**  
1000 hours



**Water pump service**  
1000 hours

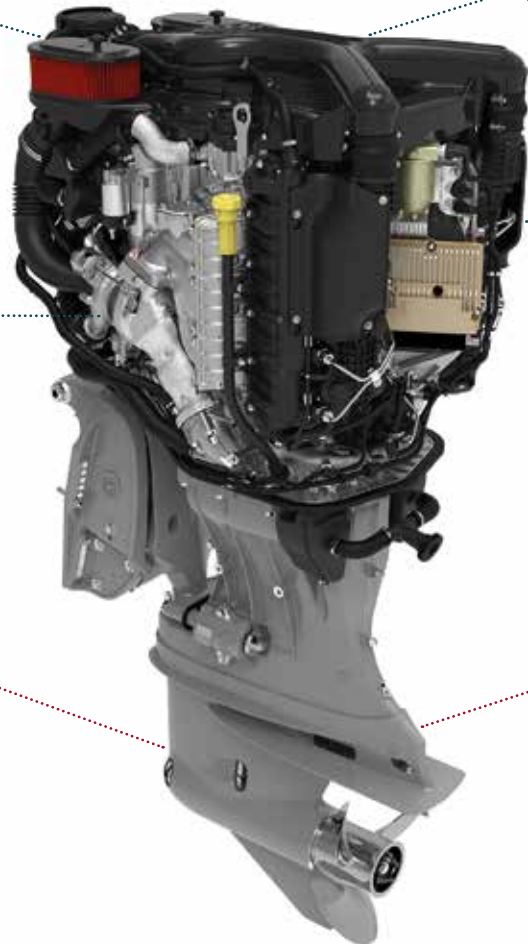

# WORLDWIDE DISTRIBUTION NETWORK



100 countries covered



35 distributors



400 dealers

Cox has worked tirelessly to establish the best possible team of exclusive distributors, covering 100 countries across the globe.

Each has been selected for its reputable standing within the marine industry, both for professional and recreational users. These will be joined by an expansive network of over 400 dealers worldwide who, like the distributors, will be on hand to ensure the highest levels of customer service.

Visit [www.coxmarine.com/distributors](http://www.coxmarine.com/distributors) to find out more about your local distributor.

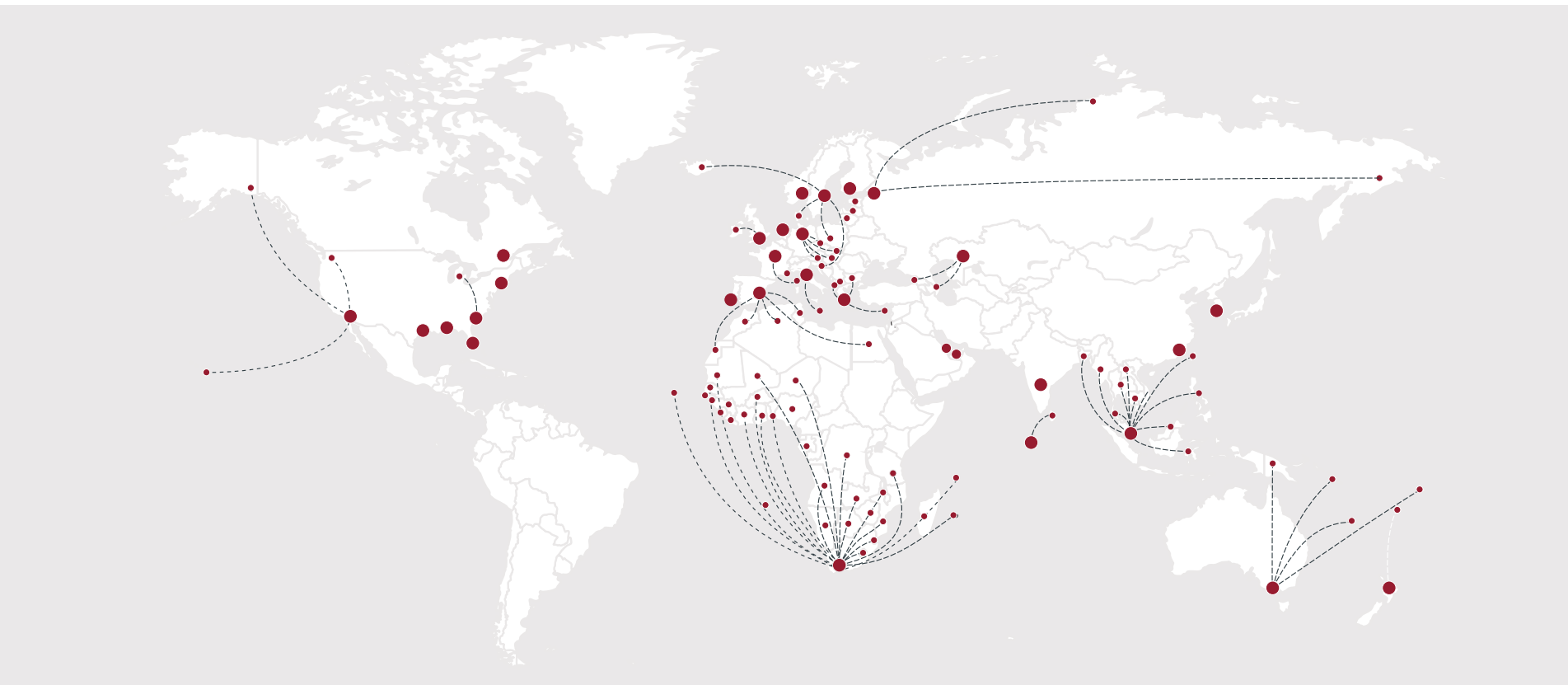

## COX POWERTRAIN LIMITED

The Cecil Pashley Building  
8 Cecil Pashley Way  
Brighton City Airport  
Shoreham-by-Sea, West Sussex  
BN43 5FF  
United Kingdom

+44 (0) 1273 454 424

marketing@coxpowertrain.com  
www.coxmarine.com



@CoxPowertrain



CoxPowertrain



Cox Powertrain



@coxpowertrain

V5 NA/INT